

**WASK - 312 BAGPIPE  
OPERATORS HANDBOOK  
P. E. MAINS**

**WASK**

**THE COMPLETE KIT IS MADE UP OF THE FOLLOWING:**

- 6 Teeset Bases complete with screw-on boss type Undercarriages.
- 4 Canopies to fit the above with integral vent Valves.
- 4 Bagpipes complete with inflation tubes and control handles.
- 4 Sets of nose and guide shoes; these being:
  - 1.1/2" nose with snap in shoes for 125 & 180 mains
  - 2" nose with snap in shoes for 250, 315 & 355 mains.
- 1 Tooling for inserting expanding stopper.
- 2 Bypass heads (side outlet)
- 6 Blanking caps.

All the equipment comes in wooden boxes with the necessary tools and instructions.

**NOTE:**

Before commencing operations with the equipment, it is recommended that the user refers to all relevant National and Local Regulations for the use of Bagpipes for stopping off gas mains to ascertain limiting pressures, allowable hole dimensions etc., which may conflict with and must take precedence over, any information given herein.

**The British Gas Corporation document PS/CP/DIS 12 entitled "CODE OF PRACTICE FOR THE USE OF BAG TUBE EQUIPMENT" should be thoroughly understood.**

## **INSTALLATION PROCEDURE**

- 1** Having cleaned the main and electrofused the Branch Saddles in the required positions (as per Table 2), secure the Teeset Bases onto the Branch Saddles using the screwed Undercarriages provided. **DO NOT OVER TIGHTEN.**
- 2** Check that the Valves slide fully and leave in the fully open position.
- 3** Fasten 56mm Cutter onto the Drill Spindle Assembly, fit Spindle into Drilling Head retaining it in the raised position with the Securing Pin chained to the head.
- 4** Fit the Drill Head into the Base, pressing fully home, also pressing vent button to assist this operation. Using the large Spanner provided, rotate the head clockwise to lock automatically.
- 5** Check the Valve is open and lower Cutter to main. Fit the Ratchet Handle and Swing Bridge into position (the Bridge will not go into position with Valve Plate closed thus ensuring that no accidental drilling of Valve can take place).  
  
Cut hole in normal manner taking care to avoid excessive feed. Withdraw Spindle and retain in raised position with Securing Pin. Close Valve (Note that mark on Valve actuating Spindle points to the position of the Valve Plate).
- 6** Depress the Vent button, venting Head until all pressure has been released. Keep button depressed and rotate the Drill Head **ANTICLOCKWISE** using the large Spanner. Remove the Drill Head and fit the Blanking Caps to each Base in turn.

Fit the bypass pipes, purge and commission

Prepare the 4 bagpipes as follows:-

1. Select correct nose/shoe combination (see Table 1) and screw on to bagpipes.
2. Fit correct size bags to inflation tubes and ensure joint soundness and bag condition by trial inflation.
3. Set direction collars to correct height engraved on inflation tube and also to point towards the natural curvature of the bag.
4. Deflate bags, fold and withdraw into bagpipes.
5. Fit bagpipes fully into canopies and tighten each gland nut.
6. Ensure Teeset base valves are shut and remove blanking caps.
7. Fit bagpipe and canopy assemblies into Teeset bases.
8. Attach control handles.
9. Leak test via canopy valves.

Connect vent pipes, flame traps and nitrogen cylinder.

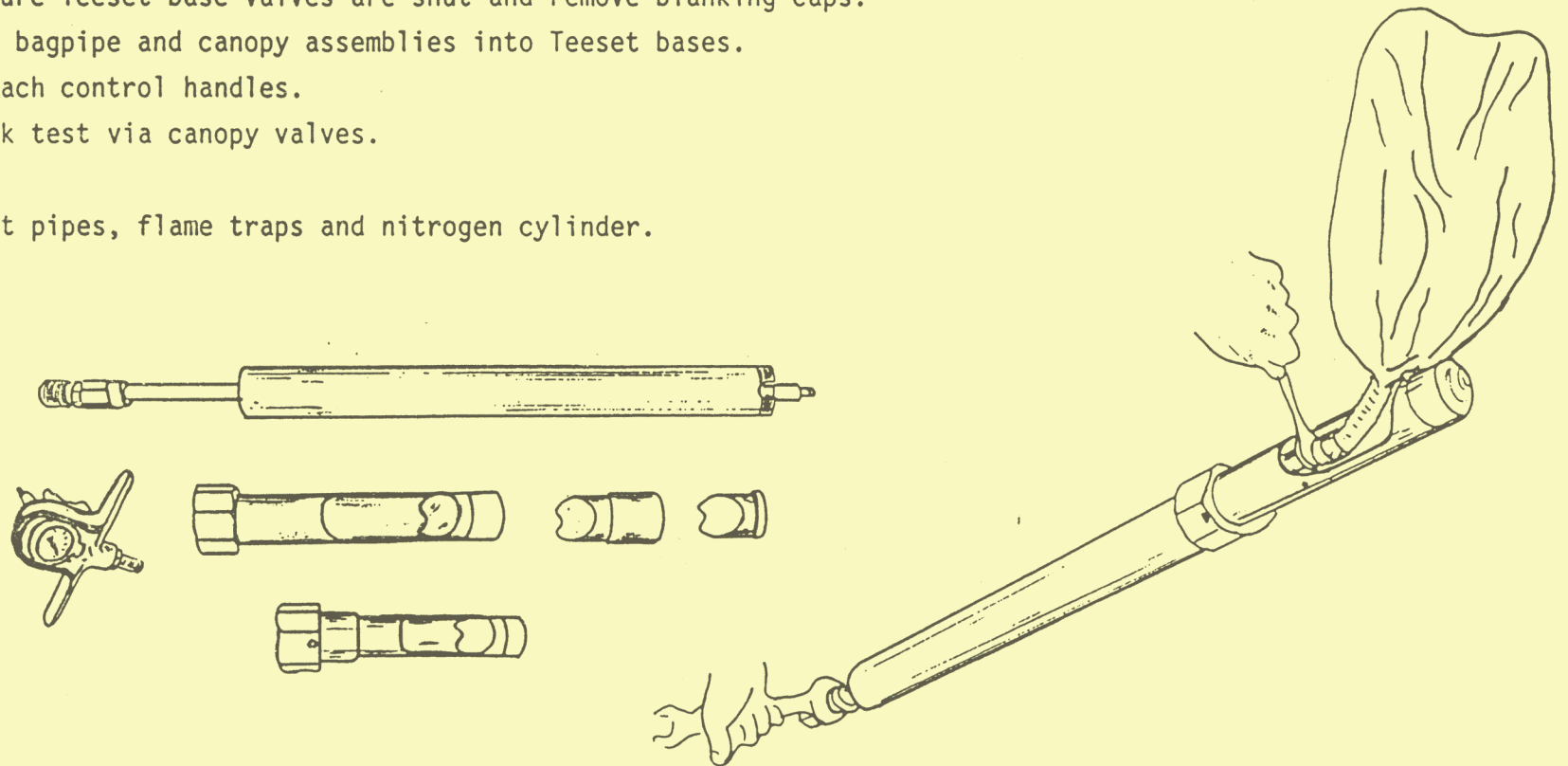

### PROCEDURE FOR INSERTING A BAG INTO THE MAIN

1. Ensure canopy valve is closed.
2. Ease off canopy gland nut until bagpipe can be moved.
3. Open base valve and push bagpipe fully into main.
4. Ensure the marking or oiler on top of the bagpipe is aligned with the main and FIRMLY TIGHTEN THE GLAND NUT.
5. Align the direction indicator collar with the main and push the handle down until the collar contacts the top of the bagpipe when the bag will be correctly placed in the main.
6. Inflate the bag to the pressure stated in the Table.

For Sequence of insertion and inflation refer to STAGE 6, 7, 8 and 9.

Cut and complete job on main, and test and purge new section.

### PROCEDURE FOR REMOVING A BAG FROM THE MAIN (ALSO FOR REPLACING A FAILED BAG)

1. Deflate bag by opening cock on handle and withdraw bag into its bagpipe.
2. Ease off the canopy gland nut, lift the bagpipe to its fullest extent and retighten the gland nut.
3. Close the base valve, relieve the pressure and remove the canopy.  
NOTE: If replacing a failed bag, disconnect it from the inflation tube and fit a new bag (which should be on hand for such an emergency) test, and re-insert into main as previously described.
4. Fit blanking cap.

For Sequence of deflation and withdrawal see STAGE 12, 13 and 14.

For dismantling Sequence see STAGE 15 and 16.

COMPLETION PROCEDURE - see STAGE 18.



**ENSURE THAT THE PIPE IS CLEAN AND THE SADDLES ARE ELECTROFUSED TO THE MAIN IN THE REQUIRED POSITIONS AS PER TABLE 2.**

**STAGE 1**

TABLE 2 - MAINS SIZES ARE TO BGC/PS/PL2 PART 1

NOM SIZE MAIN	mm	125	180	250	315	355
'A'	ins	18	20	22	24	24
	mm	450	500	550	600	600
'B'	ins	18	20	22	24	24
	mm	450	500	550	600	600
MAX MAIN PRESSURE	psi	4	4	3	1.5	1.5
	m.bar	300	300	200	100	100

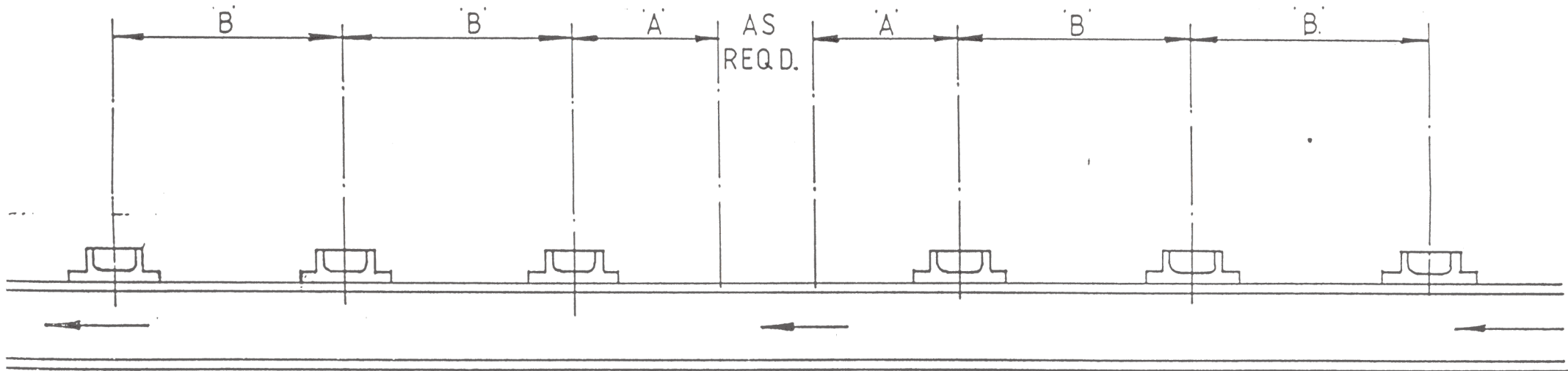

**STAGE 2**

- 1 ATTACH UNDERCARRIAGE INTO TEESET BASE USING FASTENERS PROVIDED - TIGHTEN EVENLY.
- 2 POSITION TEESET BASE AND SCREW ONTO BRANCH OUTLET SADDLE.
- 3 ENSURE VALVE PLATES ARE IN THE OPEN POSITION.
- 4 CHECK MAIN PRESSURE DOES NOT EXCEED FIGURES GIVEN IN TABLE 2.

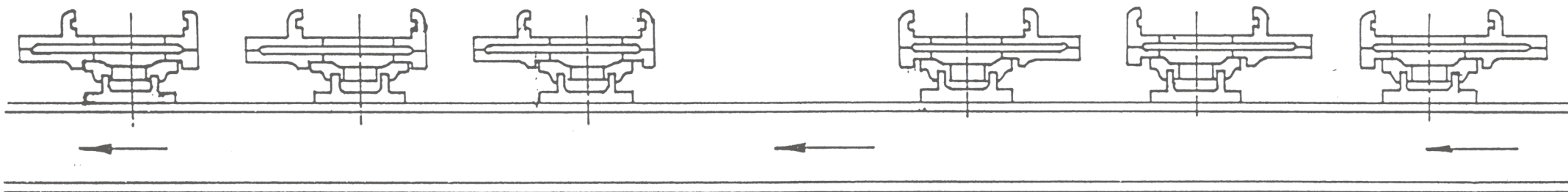



STAGE 3.

- 1 DRILL MAIN THROUGH BRANCH OUTLET WITH 56mm CUTTER.
2. CLOSING BASE VALVES AFTER WITHDRAWAL OF DRILL

NOM. SIZE MAIN.	mm.	125.	180	250.	315.	355.
HOLE SIZE.	mm.	56.				

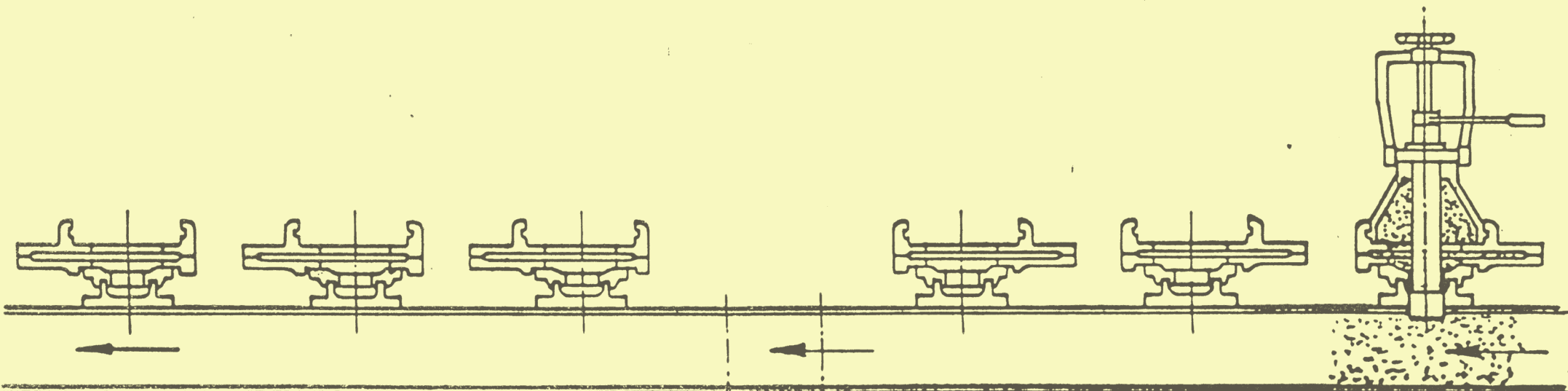

STAGE 3 CONT.

3. REMOVE UNIVERSAL DRILLING HEAD.
4. FIT BLANKING CAPS TO EACH BASE IN TURN.

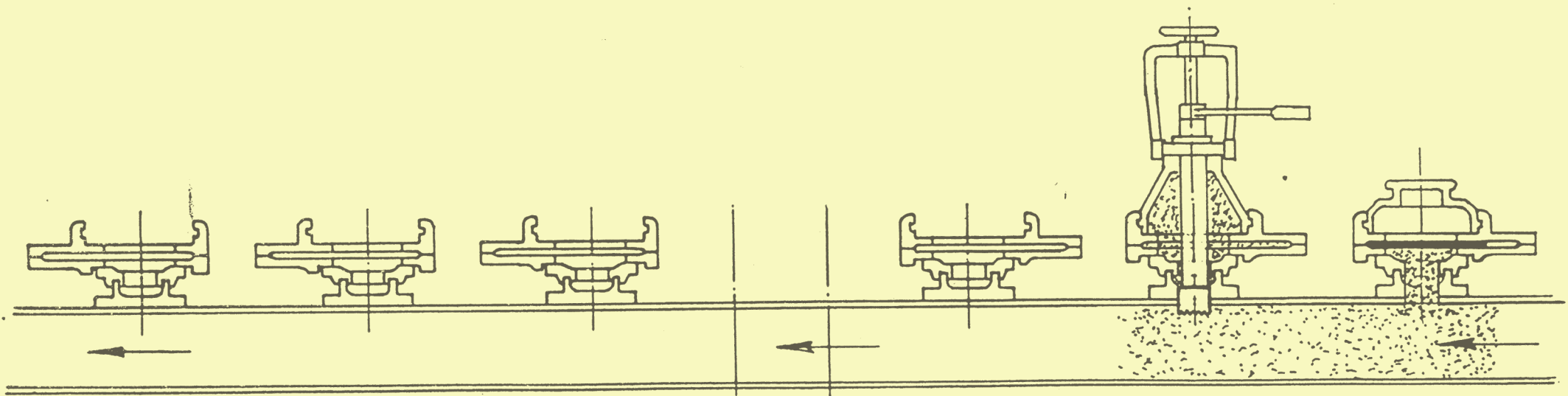

STAGE 4.

1. REMOVE OUTER BLANKING CAPS.
2. FIT BYPASS HEADS, & ASSEMBLE BYPASS PIPE.
3. FIT FLAME TRAP TO DOWNSTREAM BYPASS HEAD VALVE.
4. LEAK TEST BYPASS THROUGH UPSTREAM BYPASS HEAD VALVE.

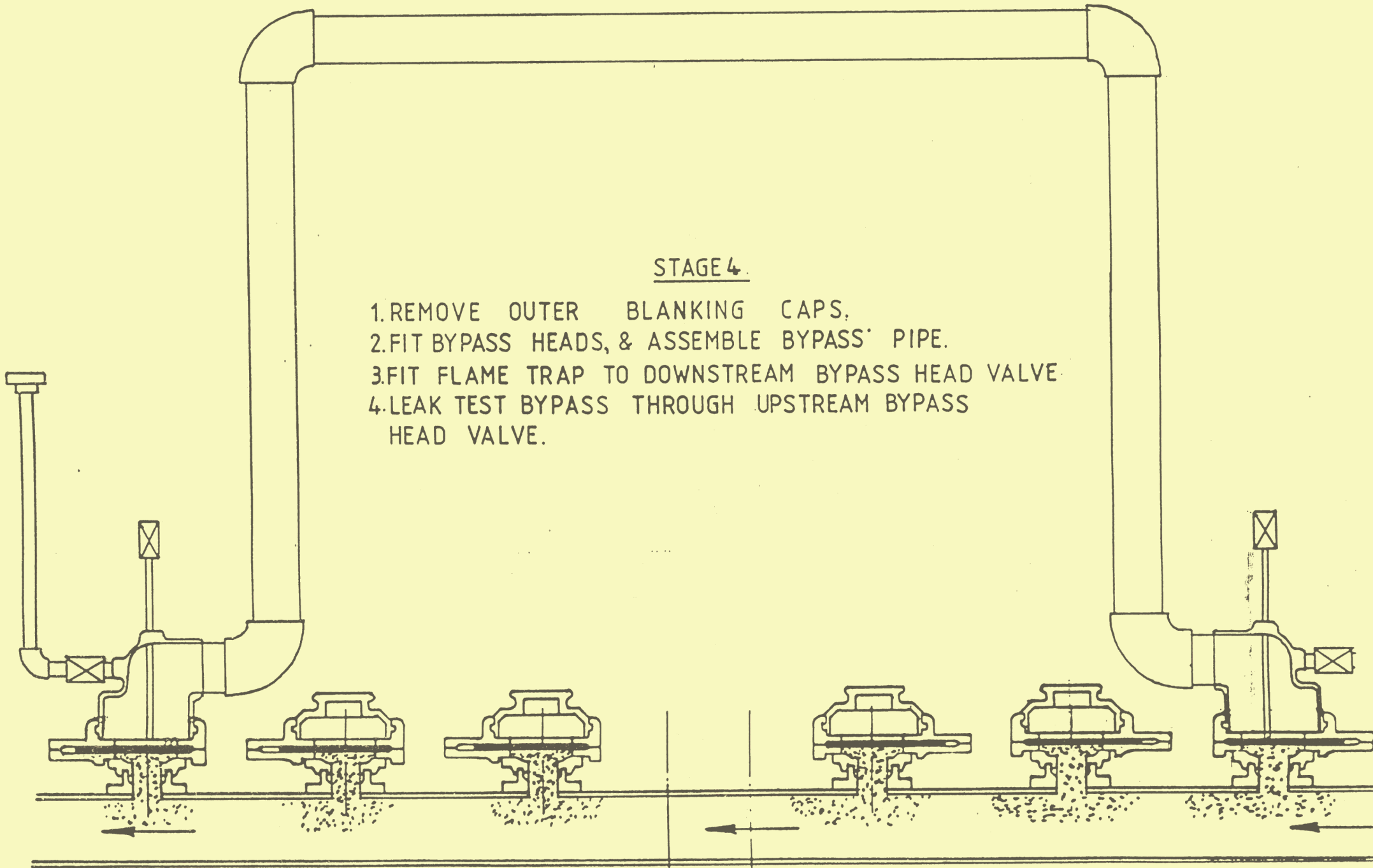

STAGE 4 CONT.

5. OPEN UPSTREAM BYPASS BASE VALVE TO GAS BYPASS &
6. PURGE BYPASS THROUGH DOWNSTREAM BYPASS HEAD FLAME TRAP
7. INSERT UPSTREAM PRESSURE PROBE & CONNECT GAUGE / RECORDER.

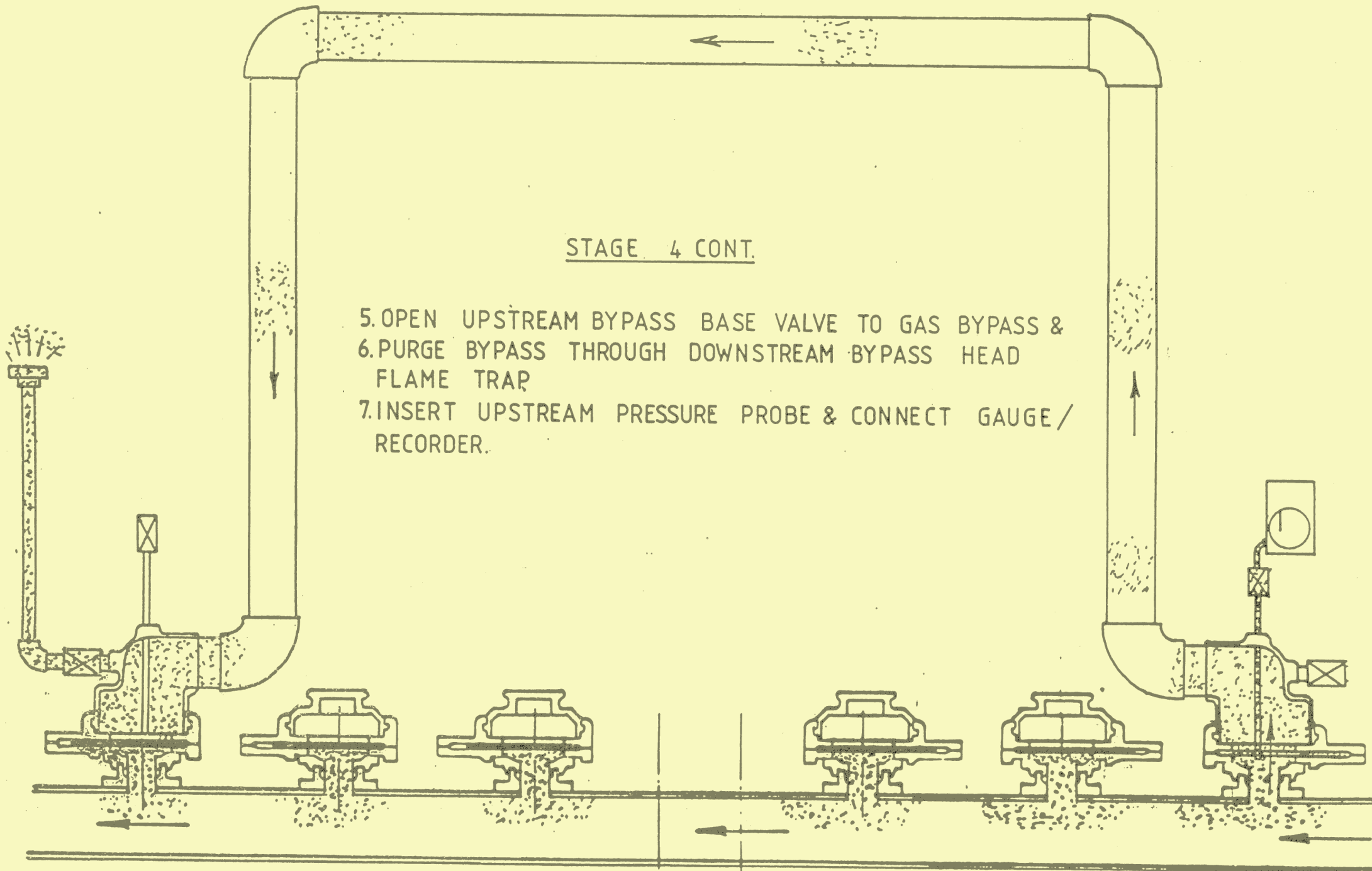

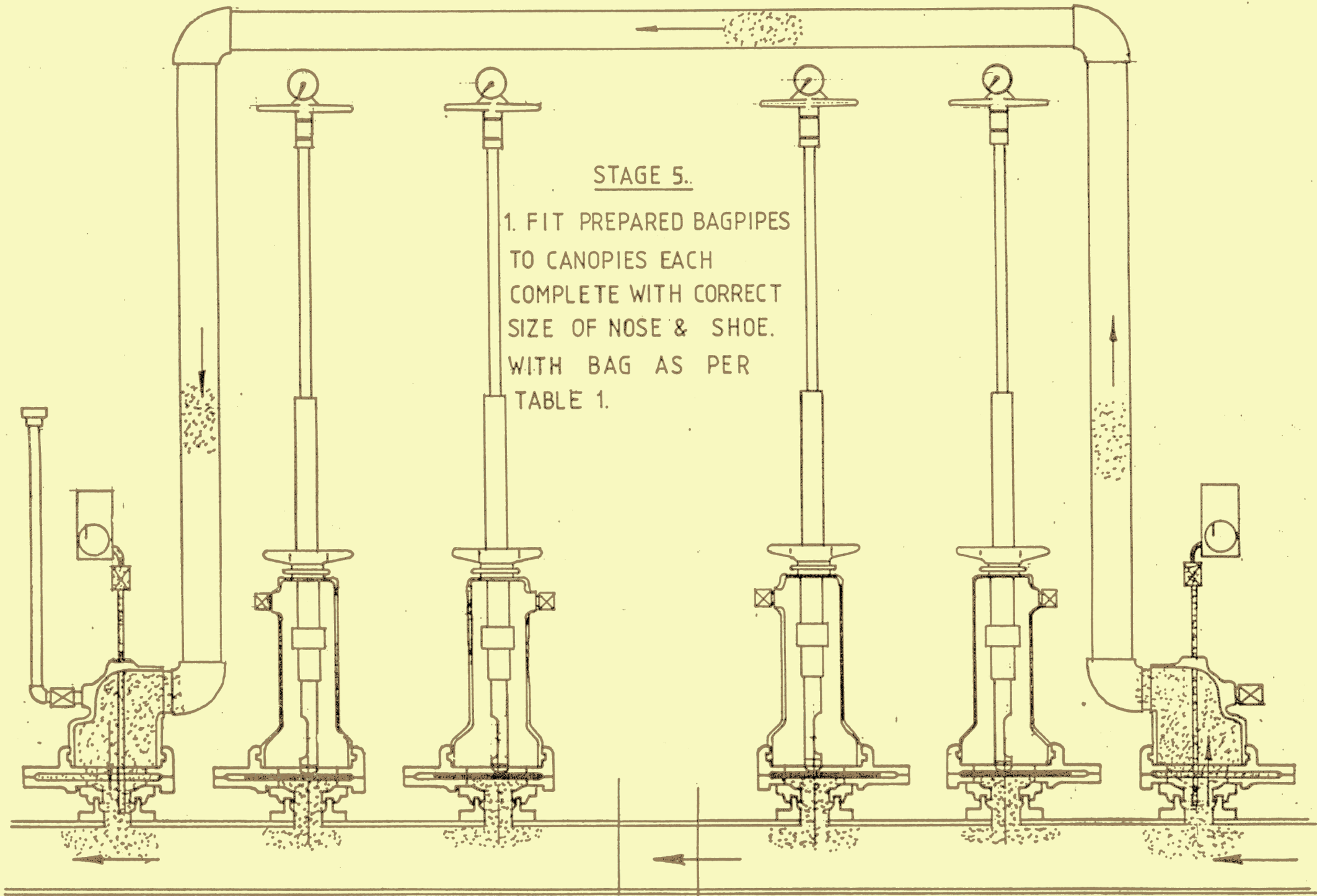

STAGE 5.

1. FIT PREPARED BAGPIPES  
TO CANOPIES EACH  
COMPLETE WITH CORRECT  
SIZE OF NOSE & SHOE.  
WITH BAG AS PER  
TABLE 1.

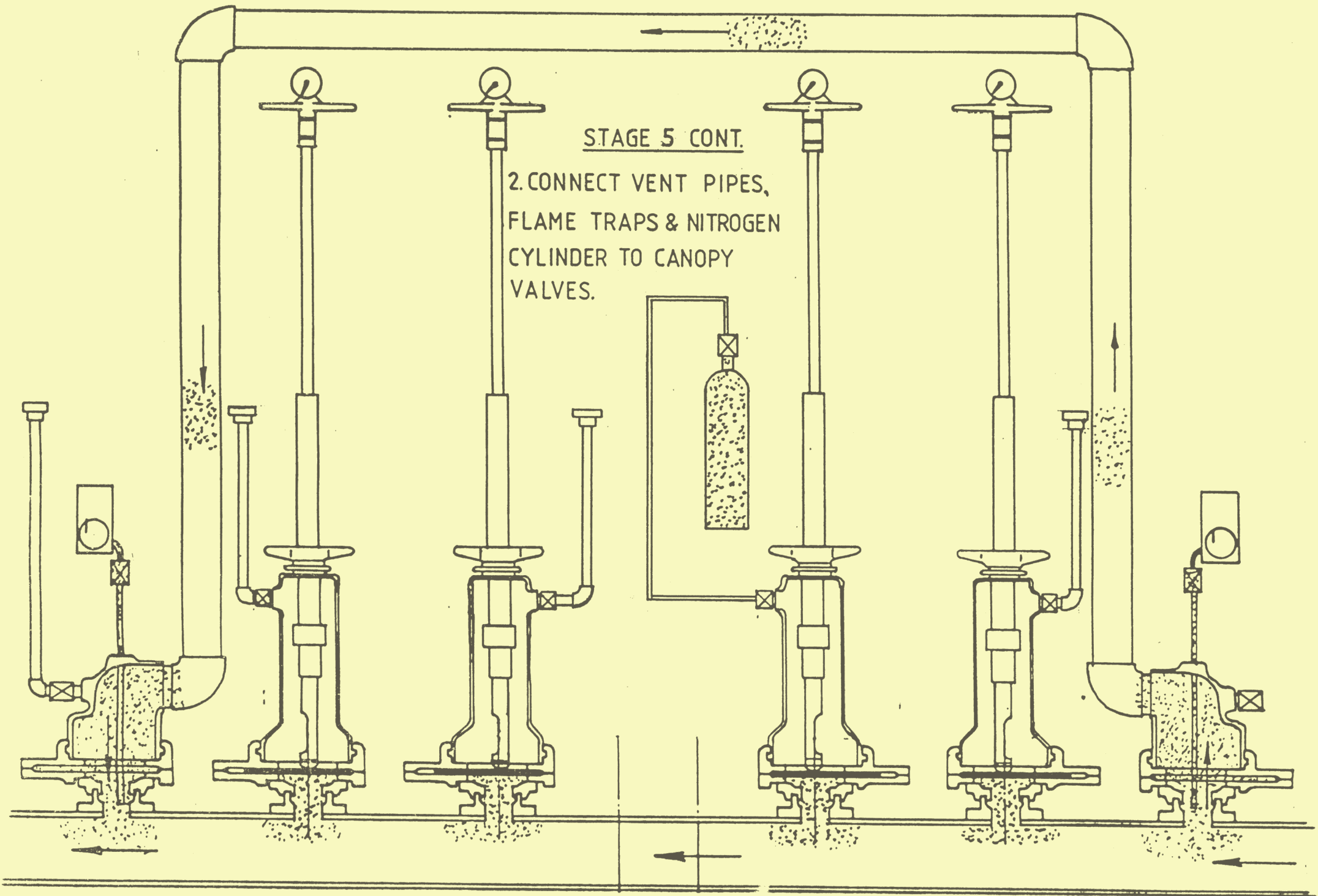

STAGE 5 CONT.

2. CONNECT VENT PIPES,  
FLAME TRAPS & NITROGEN  
CYLINDER TO CANOPY  
VALVES.

**STAGE 6.**

1. INSERT DOWNSTREAM SECONDARY BAG.
2. INFLATE TO PRESSURE STATED IN TABLE.

NOM. SIZE MAIN.	mm.	125	180	250	315	355
INFLATION PRESS.	psi.	8	8	5	4	4
	mbar.	550	550	350	300	300.

3. CHECK BYPASS FLOW SATISFACTORY.

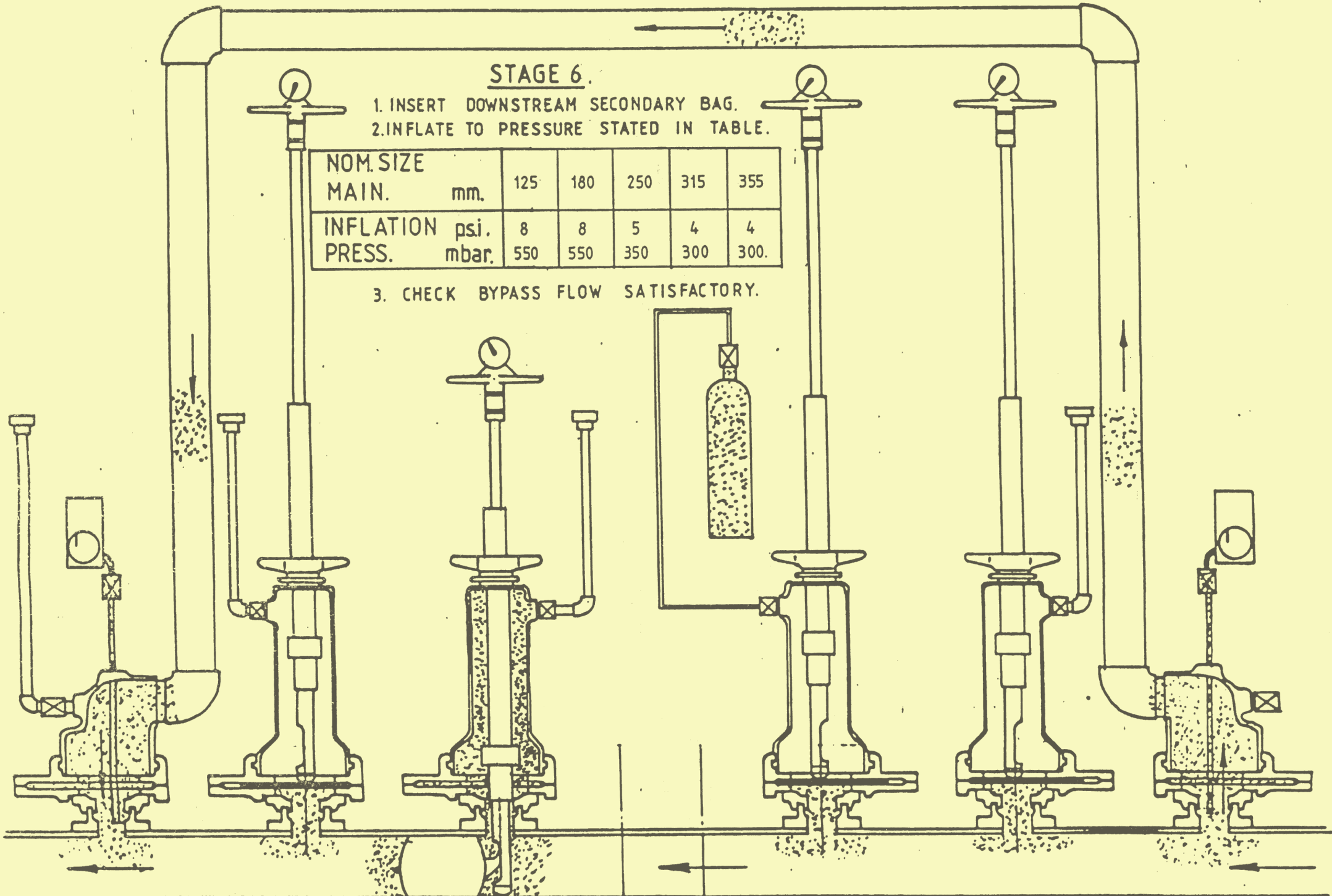

STAGE 7.

1. INSERT UPSTREAM SECONDARY BAG.
2. INFLATE TO RECOMMENDED PRESSURE.
3. OPEN SECONDARY CANOPY VALVE.
4. IF LEAKAGE RATE EXCESSIVE CLOSE VALVE, DEFLATE BAGS, REPOSITION, REFLATE, OPEN VALVE ETC. UNTIL LEAKAGE IS MINIMISED.

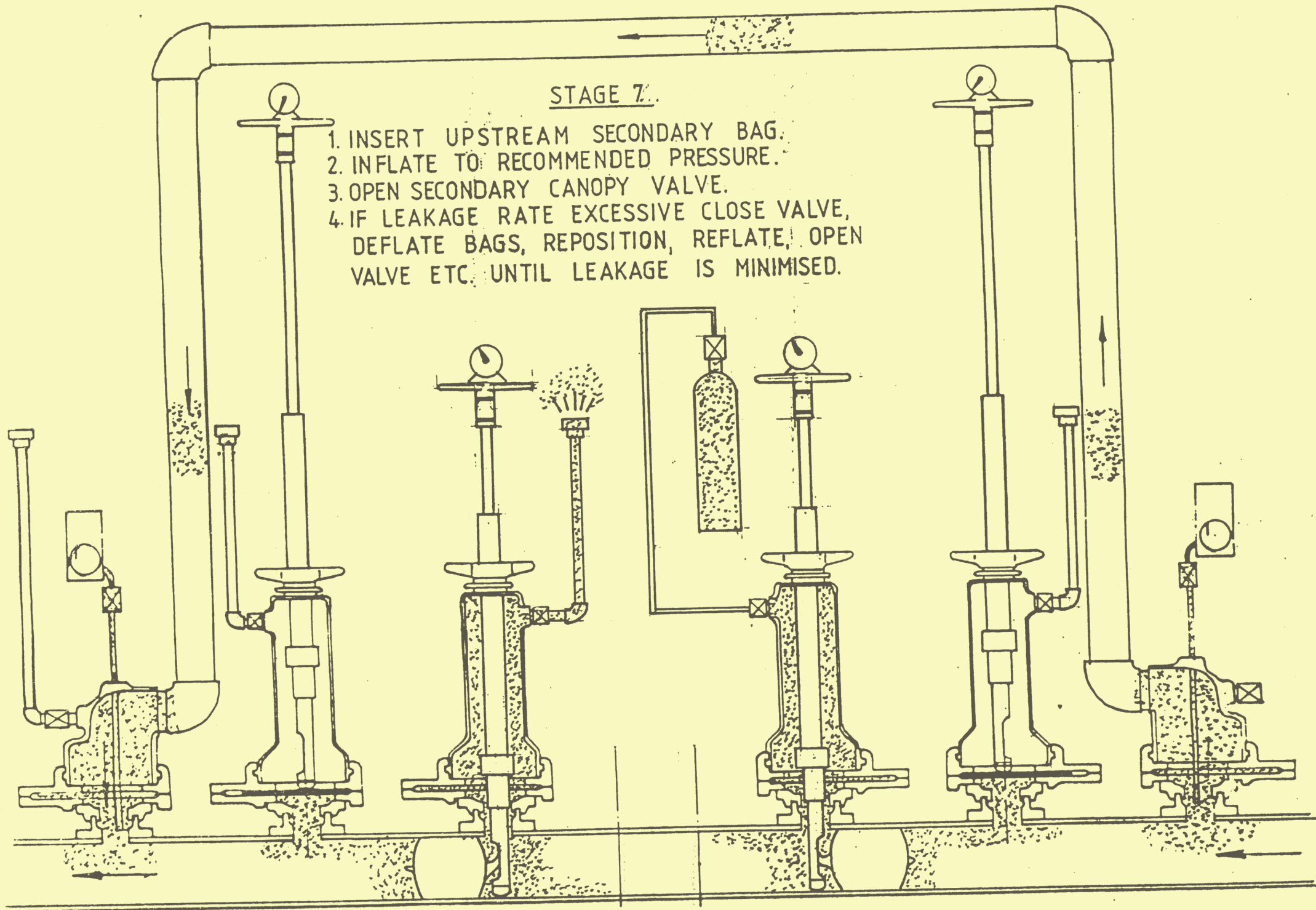



STAGE 8.

1. INSERT UPSTREAM PRIMARY BAG.
2. INFLATE TO RECOMMENDED PRESSURE.
3. OPEN UPSTREAM PRIMARY CANOPY VALVE.

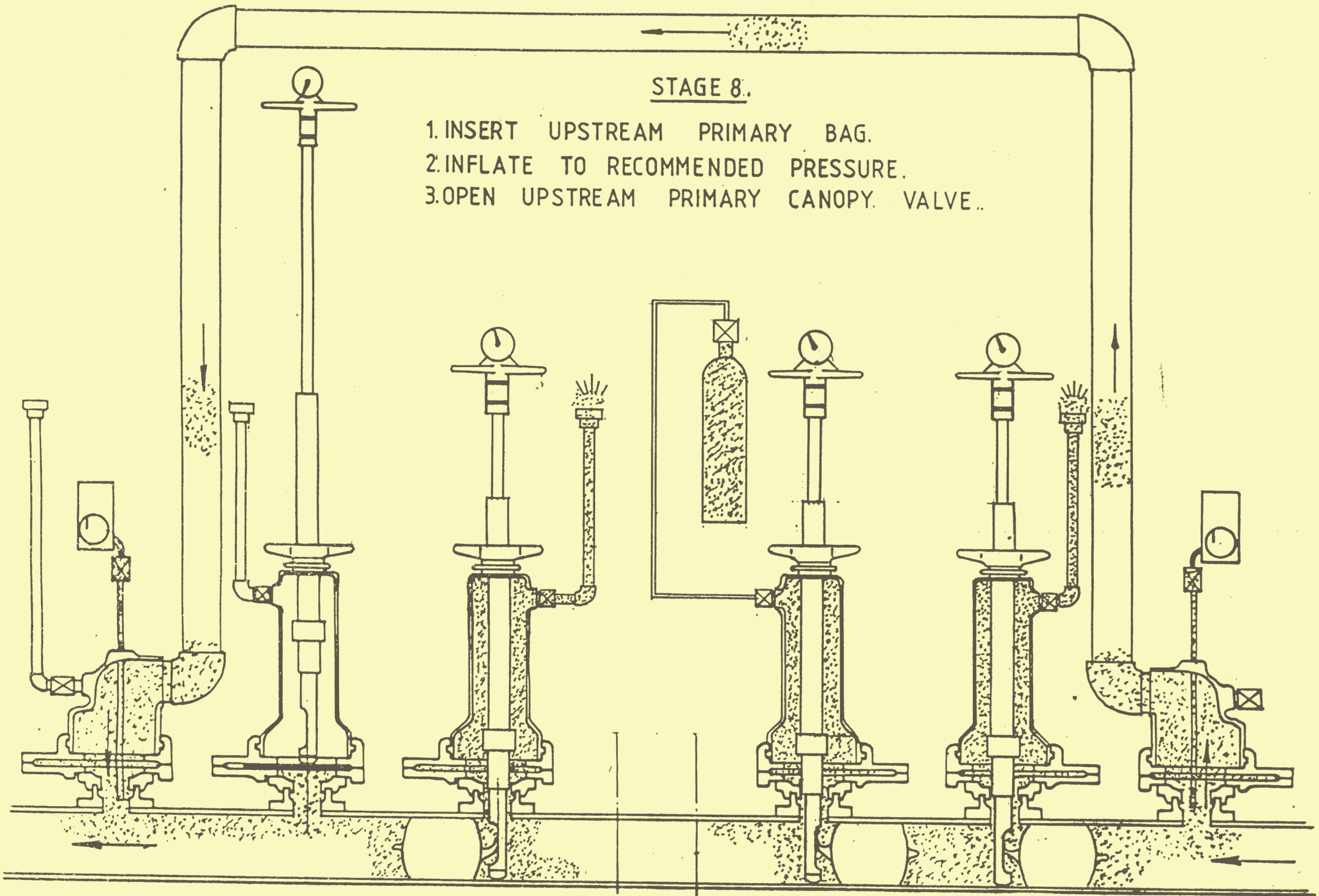

STAGE 9.

1. INSERT DOWNSTREAM PRIMARY BAG.
2. INFLATE TO RECOMMENDED PRESSURE
3. OPEN DOWNSTREAM CANOPY VALVE.
4. PURGE CENTRE SECTION WITH NITROGEN.

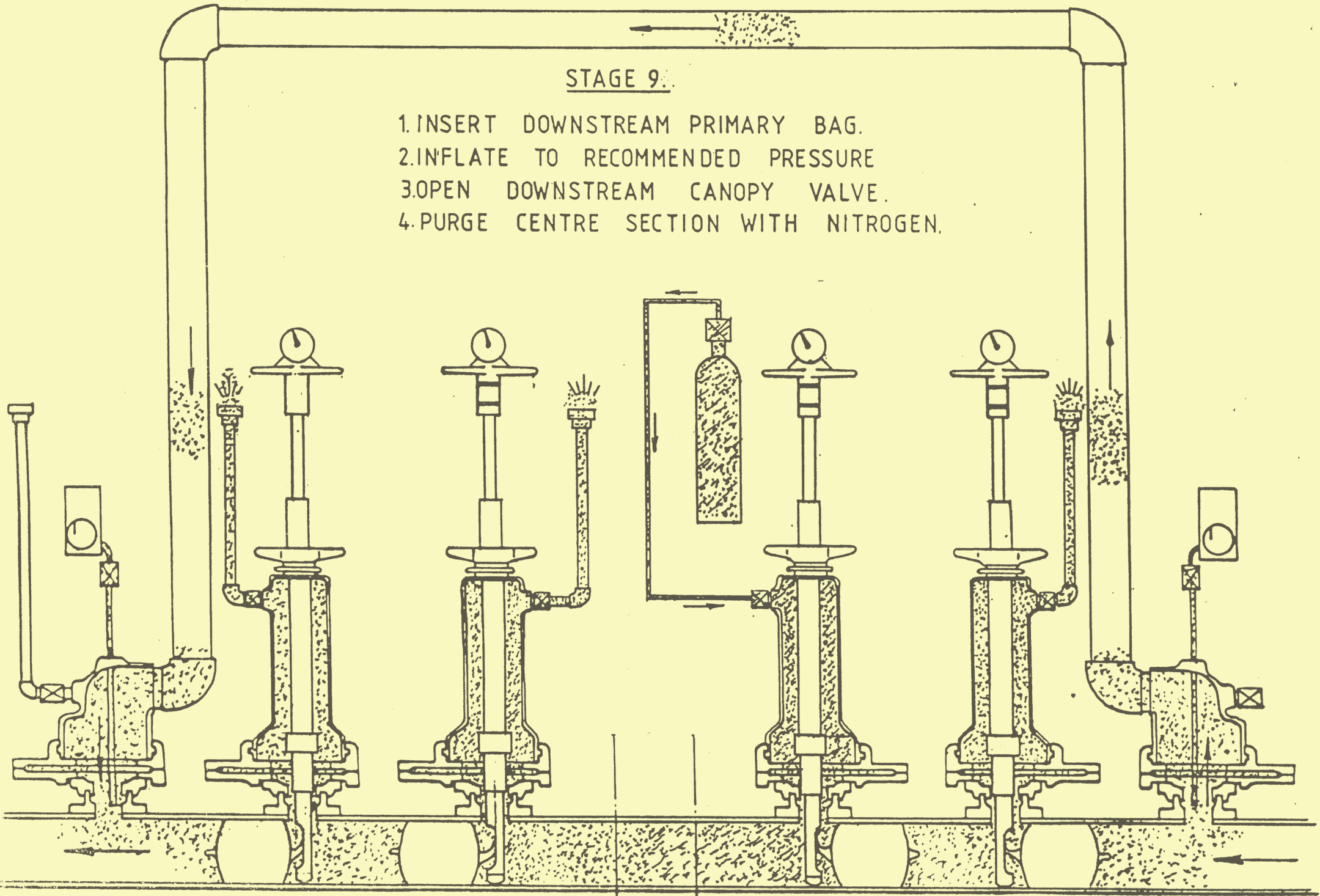

STAGE 10.

1. WHEN 'BLOW-OFF ACCEPTABLE SHUT OFF NITROGEN SUPPLY.
2. CUT MAIN AS REQUIRED.

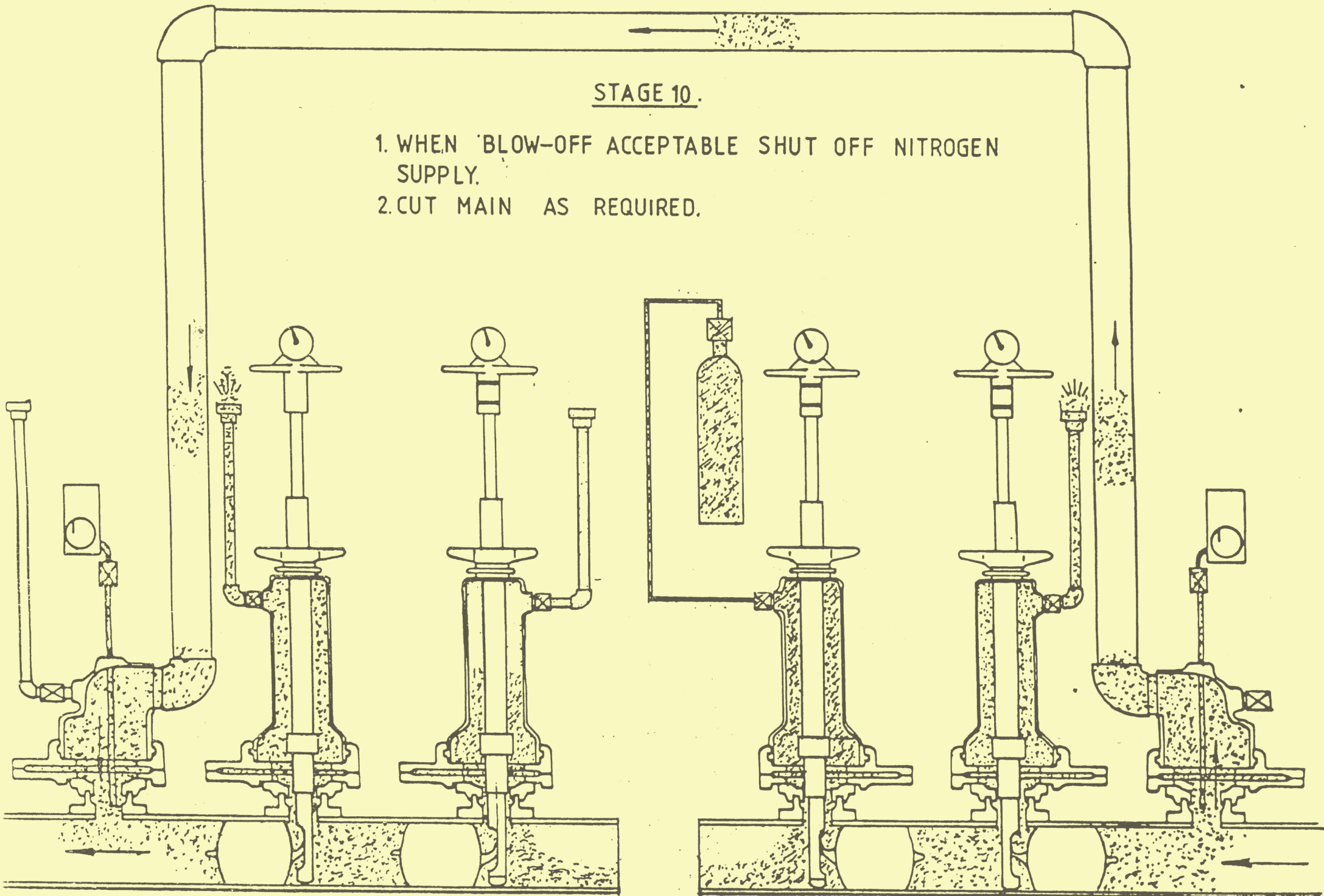

STAGE 10 CONT.

3. COMPLETE NECESSARY WORK ON CUT-OUT SECTION OF MAIN.
4. USE NITROGEN TO RE-PRESSURISE NEW SECTION EQUAL TO GAS PRESSURE.
5. TEST NEW SECTION FOR LEAKS.

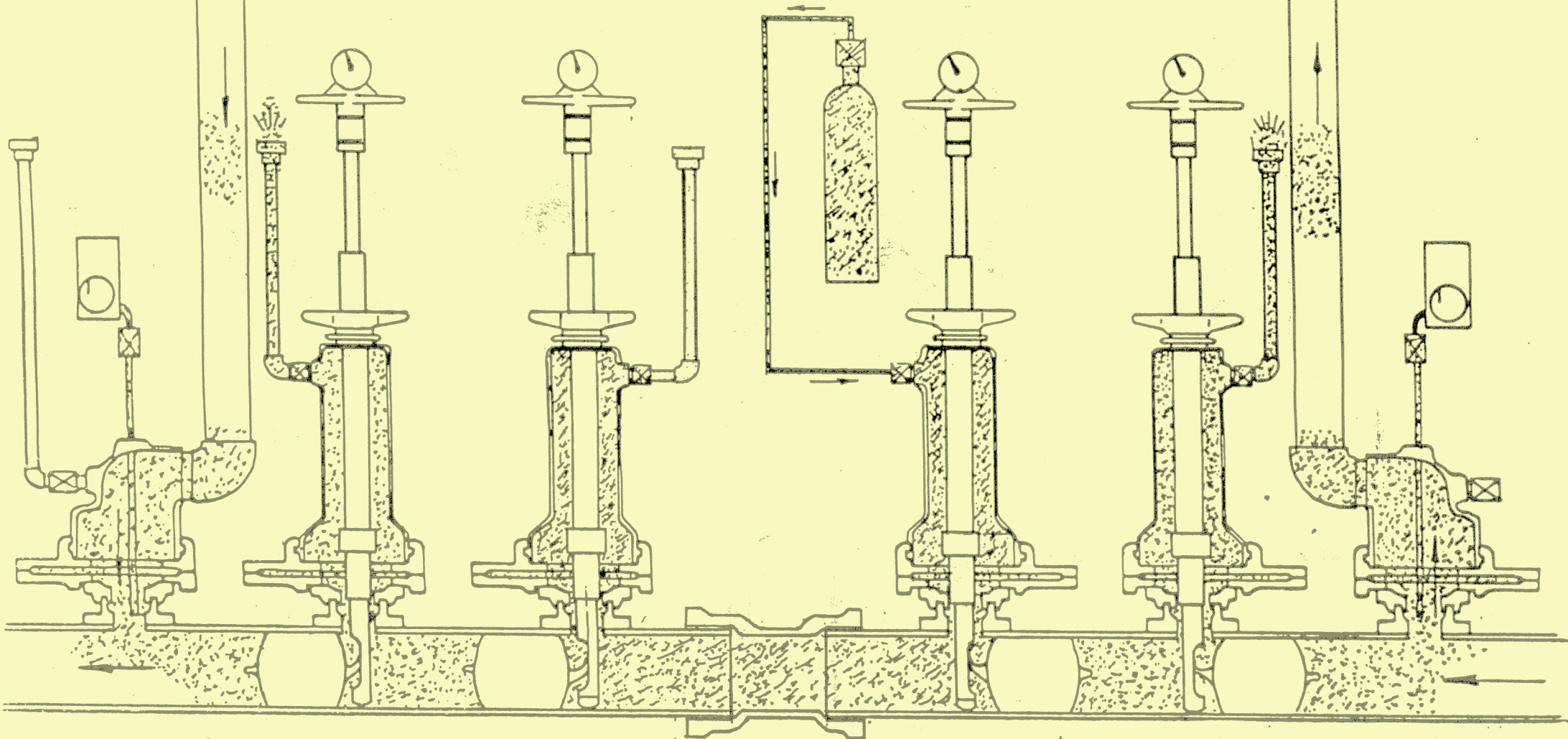

STAGE 11.

1. CLOSE UPSTREAM PRIMARY CANOPY VALVE & REMOVE VENT PIPE.
2. CONNECT RIDER BETWEEN UPSTREAM PRIMARY CANOPY VALVE & UPSTREAM BYPASS HEAD VALVE.
3. REPLACE SECONDARY VENT PIPE & RE-OPEN BYPASS CANOPY VALVE.
4. PURGE NEW SECTION WITH NITROGEN.
5. WHEN BLOW-OFF ACCEPTABLE SHUT OFF NITROGEN SUPPLY.

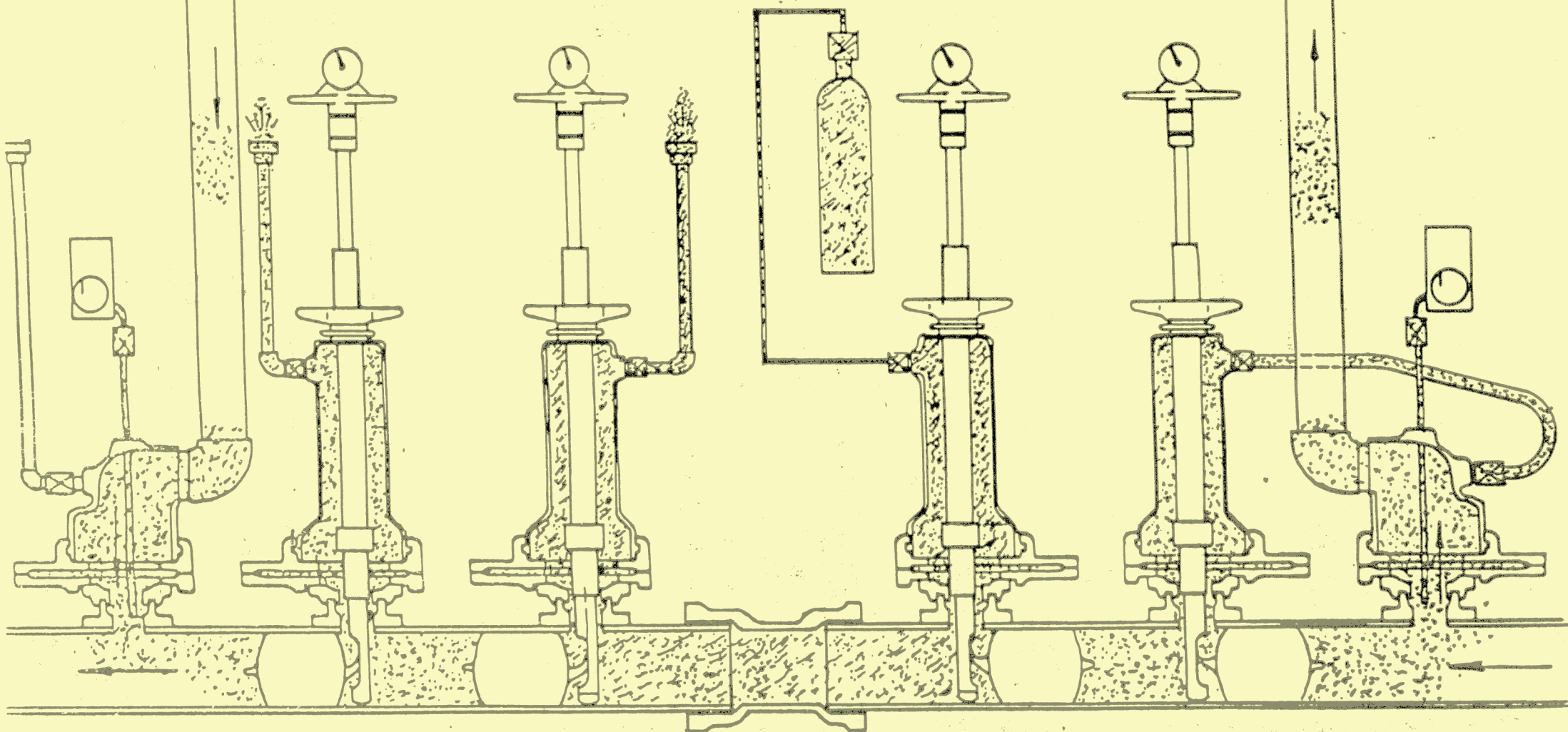

STAGE 12.

1. DEFLATE SECONDARY BAGS.
2. REMOVE NITROGEN CYLINDER & SECONDARY VENT PIPE.
3. OPEN RIDER VALVES & GAS UP NEW SECTION OF MAIN USING DOWNSTREAM PRIMARY CANOPY VALVE VENT PIPE.
4. WHEN BLOW-OFF ACCEPTABLE CLOSE VALVE & REMOVE VENT PIPE.

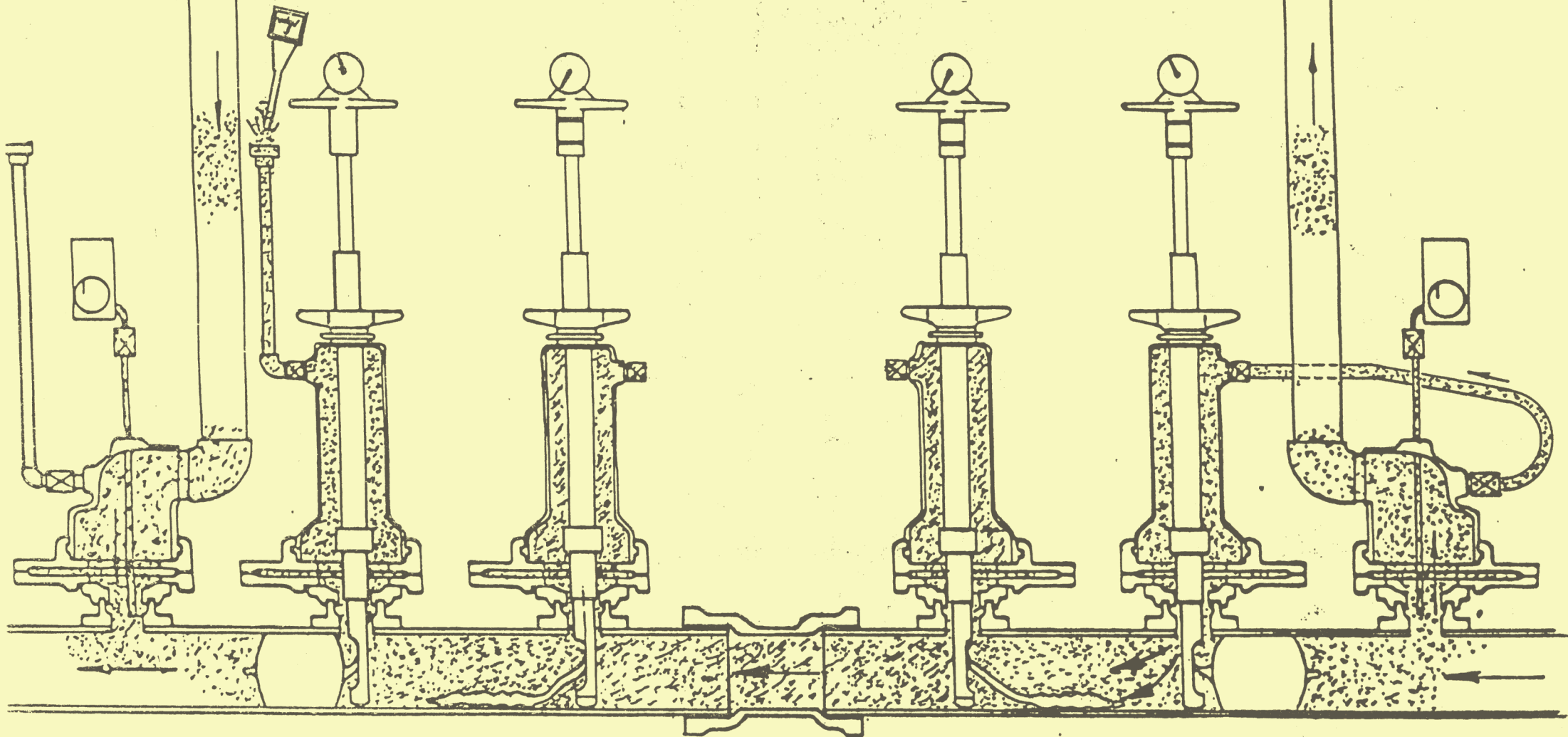

STAGE 13.

1. RETRACT SECONDARY BAGS INTO BAGPIPES.
2. RAISE SECONDARY BAGPIPES.
3. CLOSE INNER BASE VALVES.
4. DEFLATE UPSTREAM PRIMARY BAG.
5. RETRACT INTO BAGPIPE.
6. RAISE BAGPIPE VALVE.
7. CLOSE BASE VALVE.

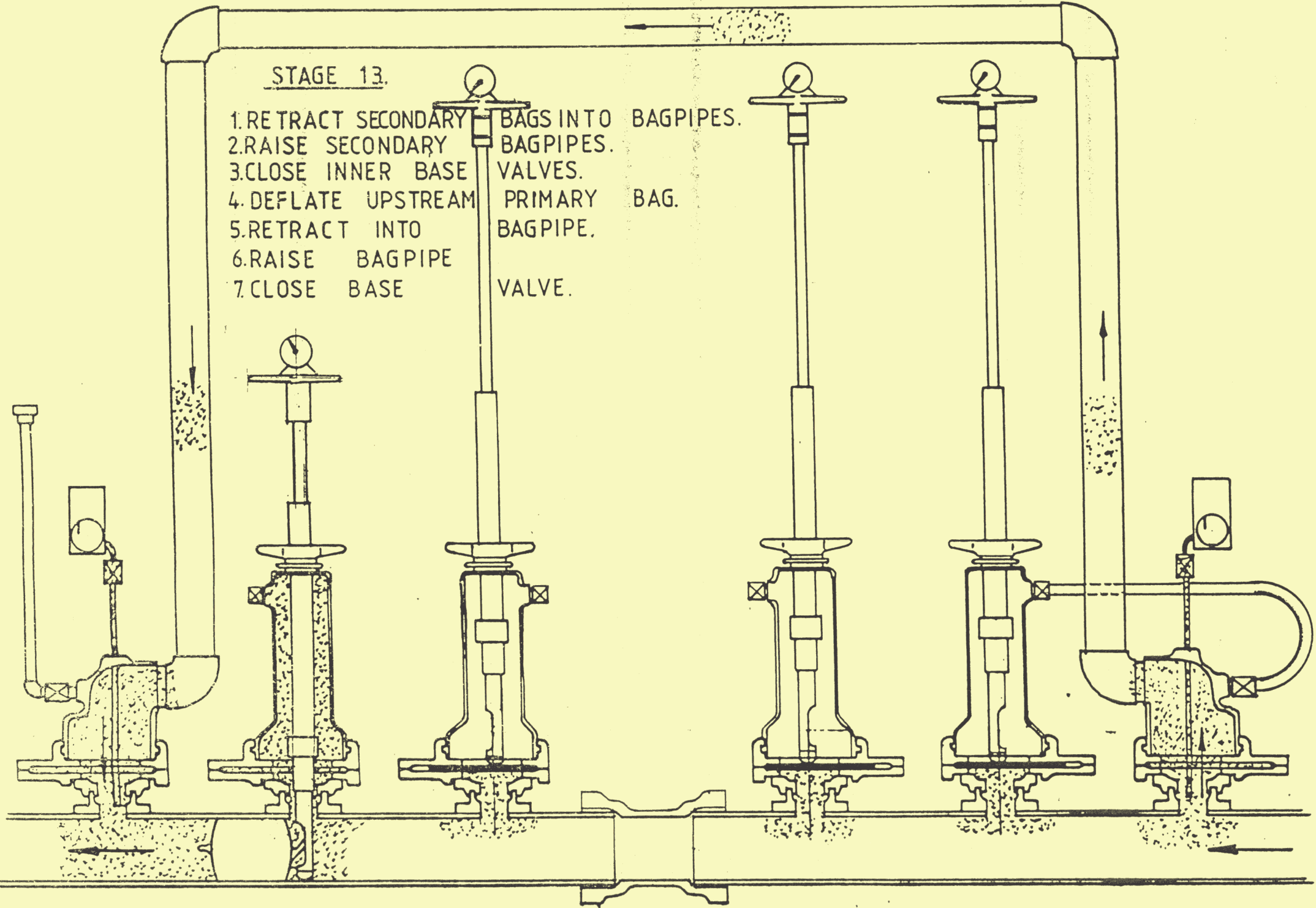

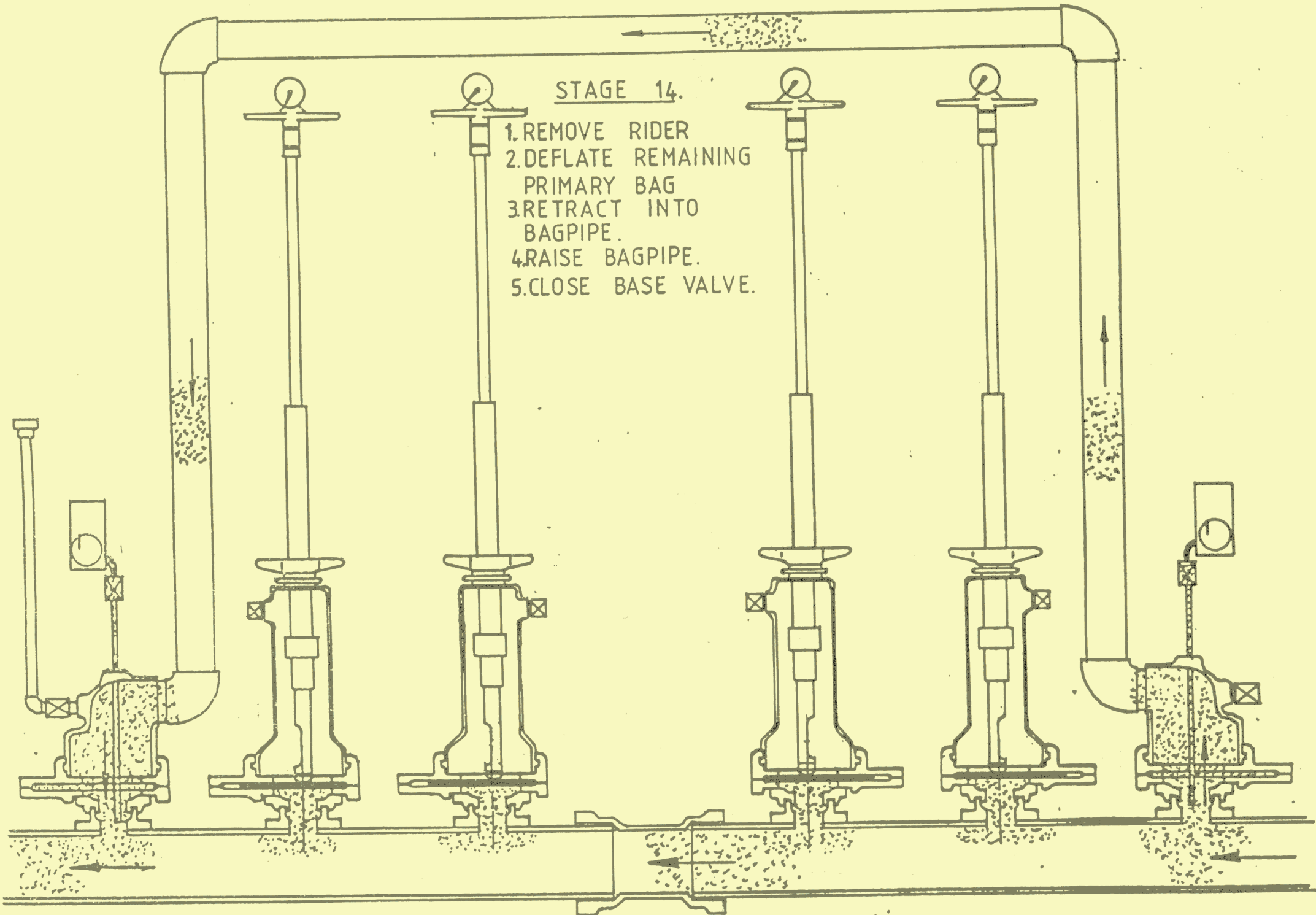



STAGE 15.

1. DISCONNECT PRESSURE RECORDERS.
2. RETRACT UPSTREAM PRESSURE PROBE & CLOSE UPSTREAM BYPASS BASE VALVE & CHECK MAIN FLOW RESTORED.
3. IF SATISFACTORY RETRACT DOWN-STREAM PRESSURE PROBE & CLOSE DOWNSTREAM BYPASS BASE VALVE.
4. CONNECT NITROGEN CYLINDER TO UPSTREAM BYPASS HEAD VALVE.
5. PURGE BYPASS THROUGH DOWN-STREAM BYPASS HEAD VALVE.

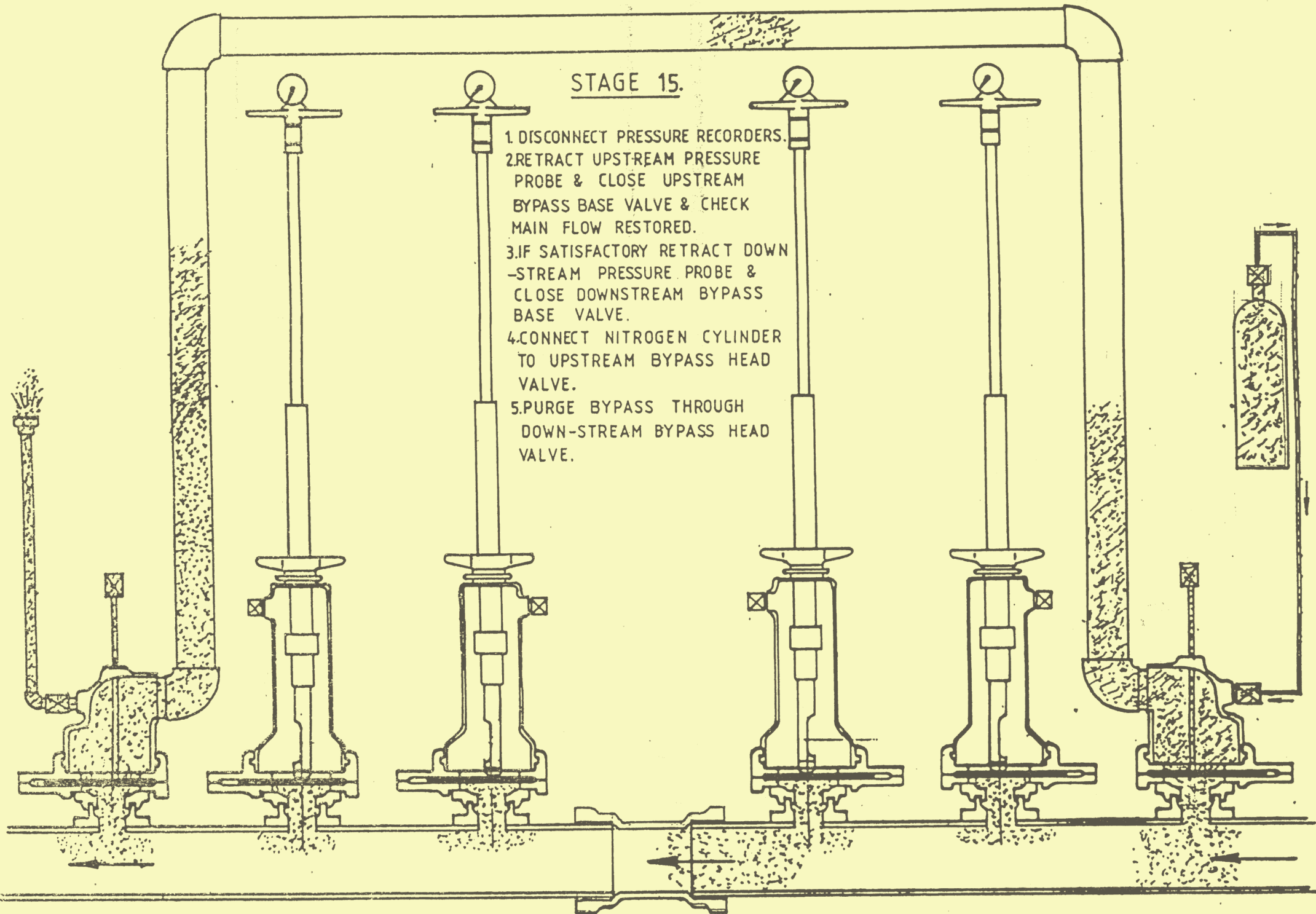

STAGE 16.

1. WHEN BLOW-OFF ACCEPTABLE  
DISCONNECT VENT PIPE &  
NITROGEN CYLINDER.
2. DISMANTLE BYPASS.
3. REMOVE BYPASS HEADS.
4. FIT BLANKING CAPS.

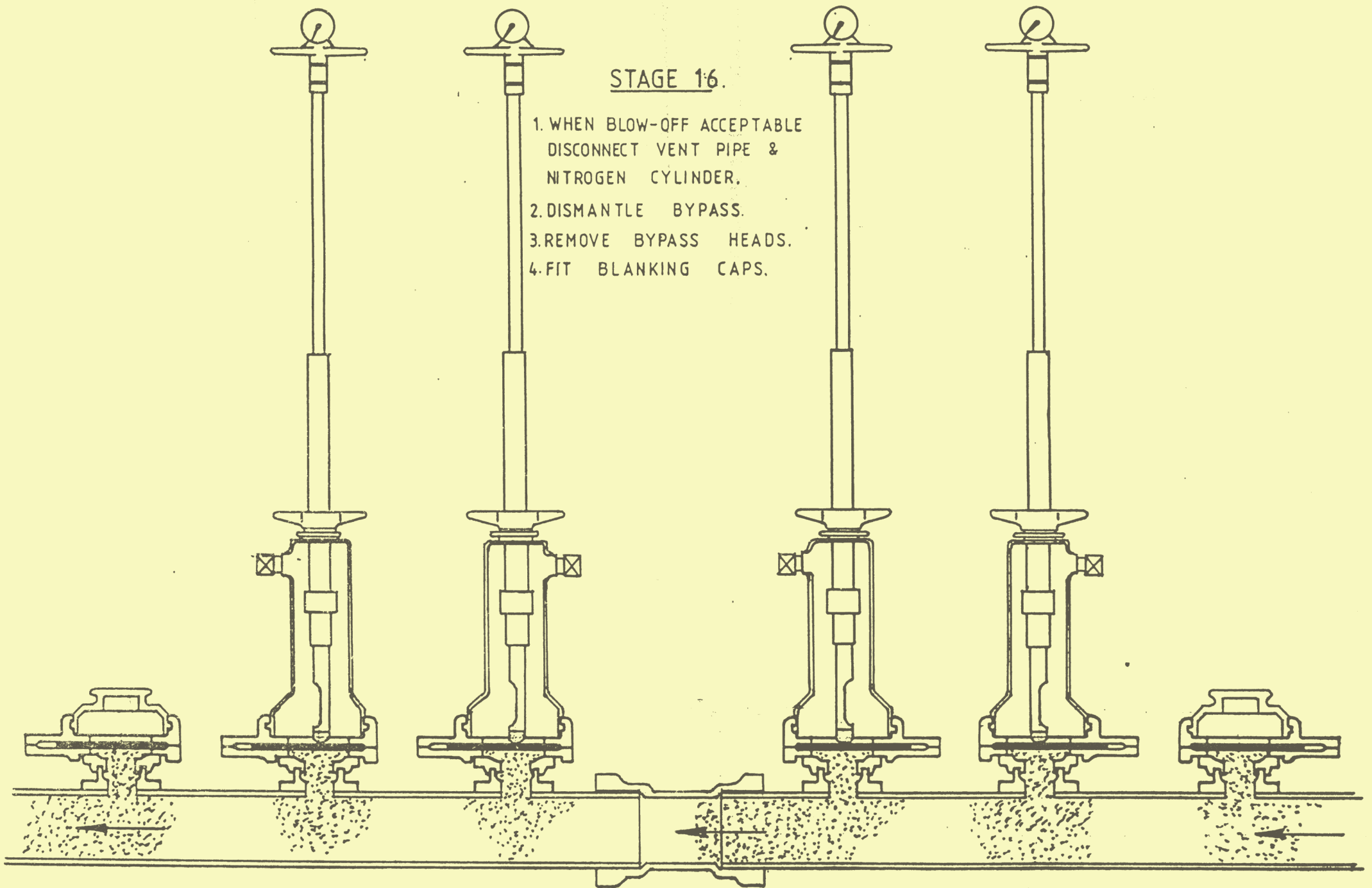

STAGE 17.

1. REMOVE THE FOUR CANOPIES COMPLETE WITH BAGPIPES.
2. FIT BLANKING CAPS IF REQD.

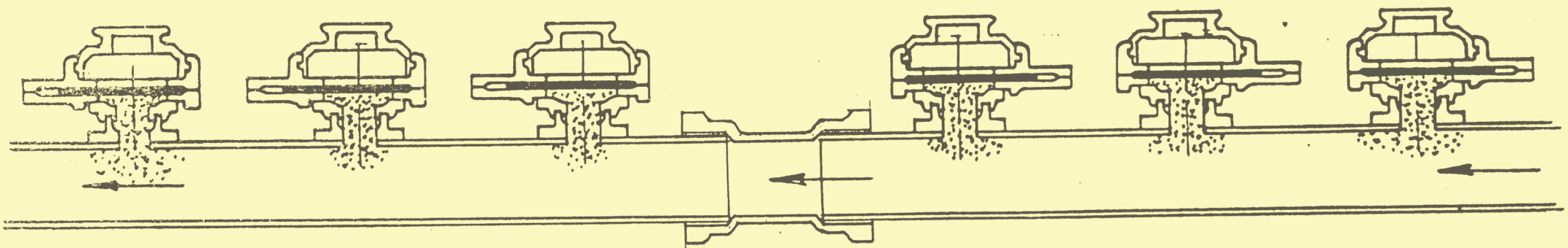

STAGE 18.

1. FIT 56mm. EXPANDING PLUG INTO ALL SIX HOLES USING TEASET FITTING HEAD & EXPANDING STOPPER FITTING SPINDLE SUPPLIED.

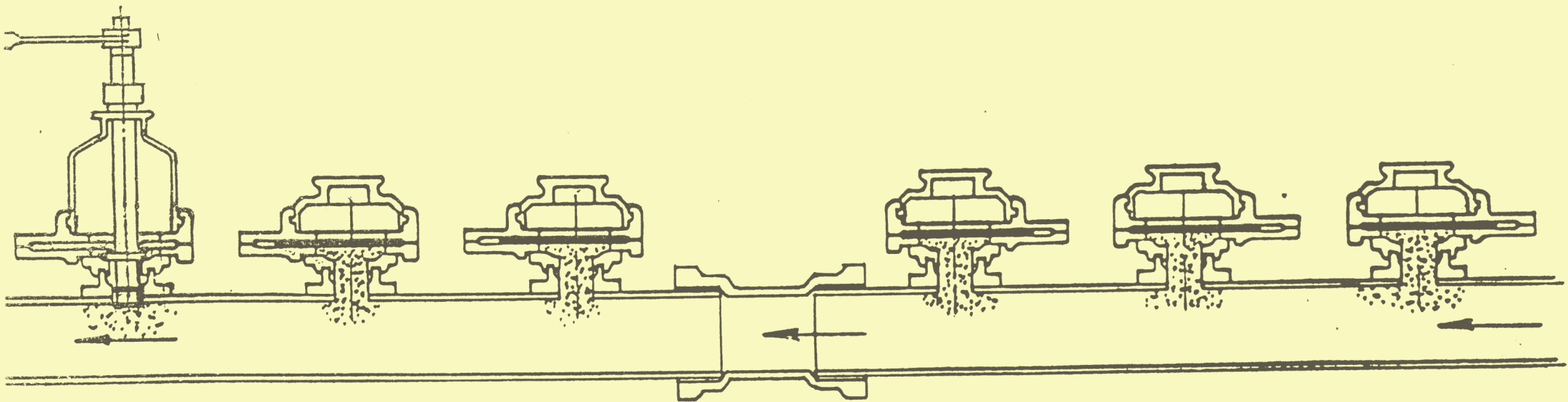

## STAGE 18 CONT.

### PROCEDURE FOR INSERTING THE EXPANDING STOPPER.

ASSEMBLE FITTING HEAD ① ALONG WITH COMPLETE FITTING SPINDLE ② & EXPANDING STOPPER ③ INTO BASE UNIT ④ PRESSING FULLY HOME. DEPRESS & HOLD DOWN VENT BUTTON. USING LARGE SPANNER PROVIDED, ROTATE FITTING HEAD ① CLOCKWISE AUTOMATICALLY LOCKING FITTING HEAD ① TO BASE UNIT. ④

OPEN BASE VALVE ⑤ & LOWER FITTING SPINDLE ② UNTIL THE FLANGE ON THE FITTING SPINDLE MAKES CONTACT WITH THE UNDERCARRIAGE ⑥ THIS POSITIONS THE STOPPER ③ IN THE MAIN.

LOCK GLAND NUT ⑦ ON FITTING HEAD ① & FIT TEESSET RATCHET SPANNER OVER SQUARE ON TOP OF FITTING SPINDLE. ② NOW FIT SPANNER ONTO HEX. NUT OF INNER SPINDLE ⑧ & ROTATE ANTICLOCKWISE WHILST HOLDING THE RATCHET SPANNER STATIC UNTIL EXPANSION OF PLUG CAUSES THE INNER SPINDLE ⑧ TO REACH A DEFINITE STOP.

REMOVE BOTH SPANNERS RELEASE GLAND NUT ⑦ & REMOVE FITTING HEAD. ① FIT RATCHET SPANNER IN IT'S ANTICLOCKWISE POSITION DISENGAGE INNER SPINDLE ⑧ BY LIFTING UPWARDS & DISENGAGE FITTING SPINDLE ② BY ROTATING RATCHET SPANNER ANTICLOCKWISE. THE BASE ASSEMBLY ④ ⑥ CAN THEN BE REMOVED.

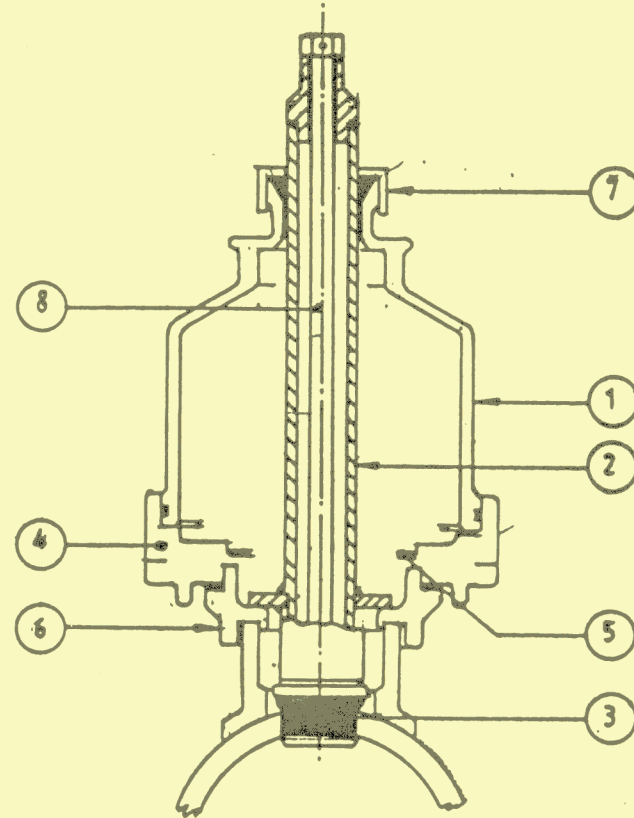

STAGE 18 CONT.

2. REMOVE BASES AS EACH PLUG IS FITTED.

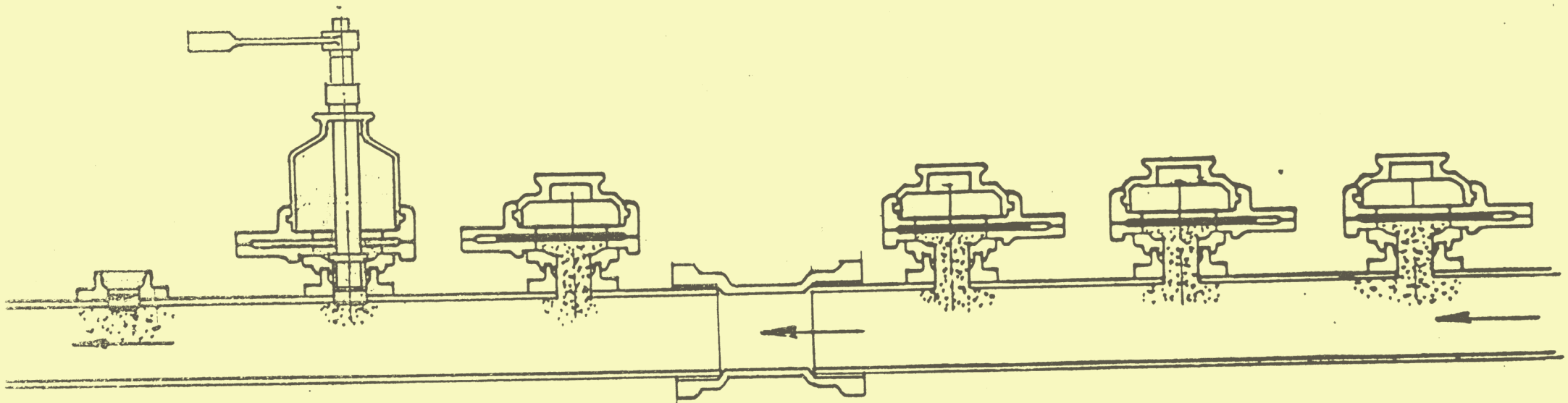

**STAGE 18 CONCLUDED**

- 3 TERMINATE WITH SCREW-ON CLOSURE CAP INTO BRANCH OUTLET ACCORDING TO RELEVANT CODE OF PRACTICE.

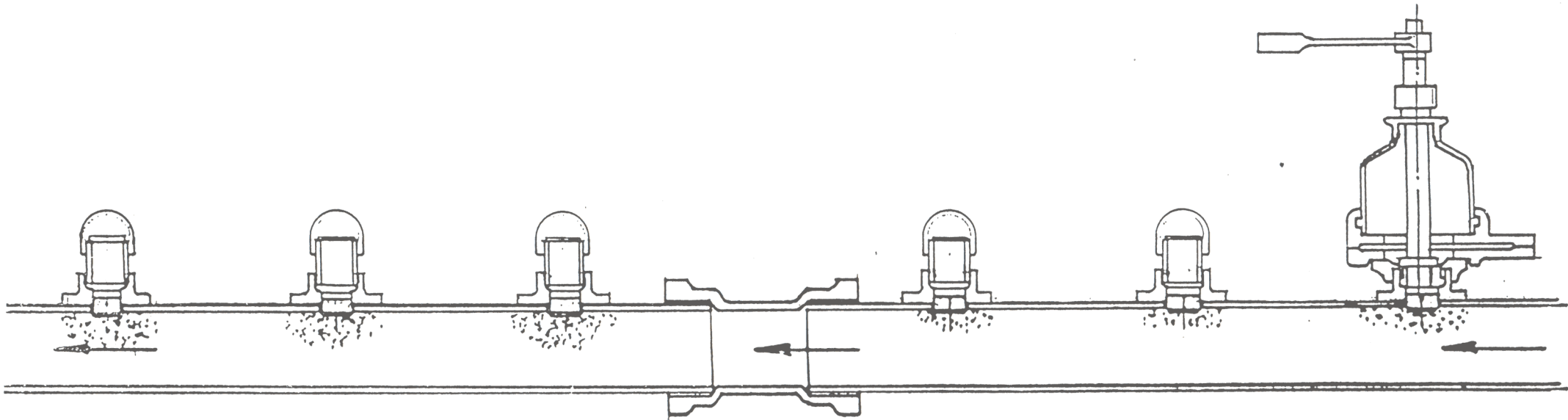

# WASK

Wask  
Nacton Road  
Ipswich  
Suffolk  
IP3 9QH

Sales Office Tel +44 (0) 1473 277412

Sales Office Fax +44 (0) 1473 277411

[www.wask-uk.com](http://www.wask-uk.com)

email :- [sales@wask-uk.com](mailto:sales@wask-uk.com)